

D/LG/KIR/N



RSC SERIES -ROTARY SCREW AIR COMPRESSORS



STANDARD EQUIPMENT

High quality components such as IP55 electric motors with the IE3 efficiency class, IP54 fan motors, star-delta motor starter system, electrical materials selected according to IEC, UL/cUL, CE standards as per the market requirements, high-efficiency screw blocks consuming less energy are provided as standard in all our products.



SERVICEABILITY

Service-friendly design implemented using a layout that provides instant access to all consumable items, with quick-release protective covers and easy-to-use controllers minimizes downtime and reduces maintenance costs.



SCREW BLOCK

Patented and durable screw block that provides high-capacity of air, and that is specially selected for each model's capacity requirement

Production of air with high volumetric efficiency, thanks to the new rotor profiles, and lower torque requirements

New generation bearing design with increased load carrying capabilities



AIR OIL SEPARATOR

Spin-on separator

Easy replacement, ease of assembly and disassembly

Design that does not require a separator tank



MAIN MOTOR AND DRIVE SYSTEM

High efficiency 400V/3 phase/50Hz, IE3 IP55 electric motors with F Class insulation

Star delta motor starting system

Easy of assembly and disassembly with bush pulleys on belt-pulley models

Direct coupled model, long-lasting and efficient transfer system thanks to use of elastic couplings





RSC SERIES Rotary Screw Air Compressors

Dalgakiran RSC series compressors are designed to meet the pressurized air requirements of rail system vehicles.

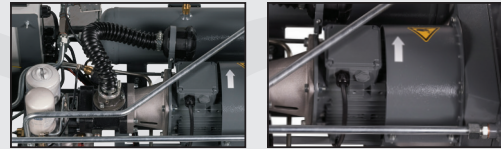

GENERAL SPECIFICATION

- Long maintenance intervals and low maintenance costs
- Optional installation on the cars (on the car, inside the car or under the car)
- Quiet operation, low vibration
- Light and compact structure
- Reliable and durable
- Directly-coupled drive system
- CE Certified air tanks complying with SPVD (Simple Pressure Vessel Directive) and designed as per EN 286-3 standard

MAIN MOTOR AND DRIVE SYSTEM

- Directly coupled with the elastic coupling

COOLING SYSTEM

- Quiet and efficient axial fan directly connected to the main motor)

SEPARATORS AND COMPACT AIR DRYER

- Cartridge type mechanical dryer that separates oil particles and aerosols
- Easy-to-detach spin-on type separator

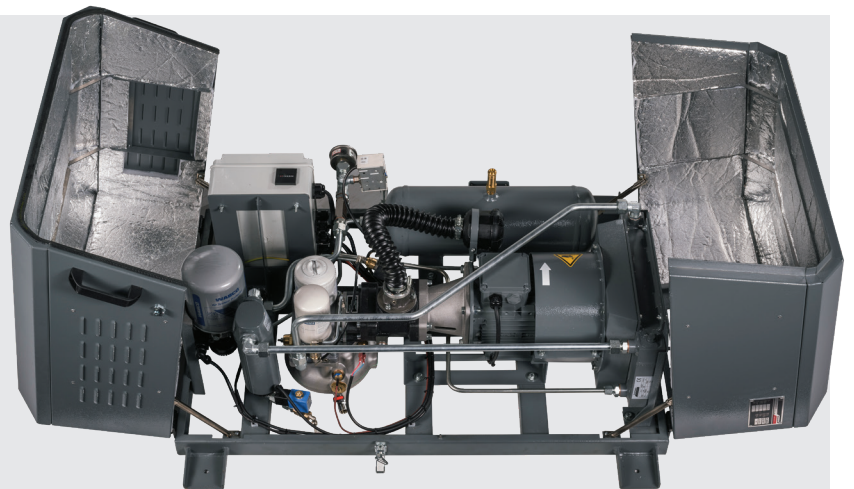

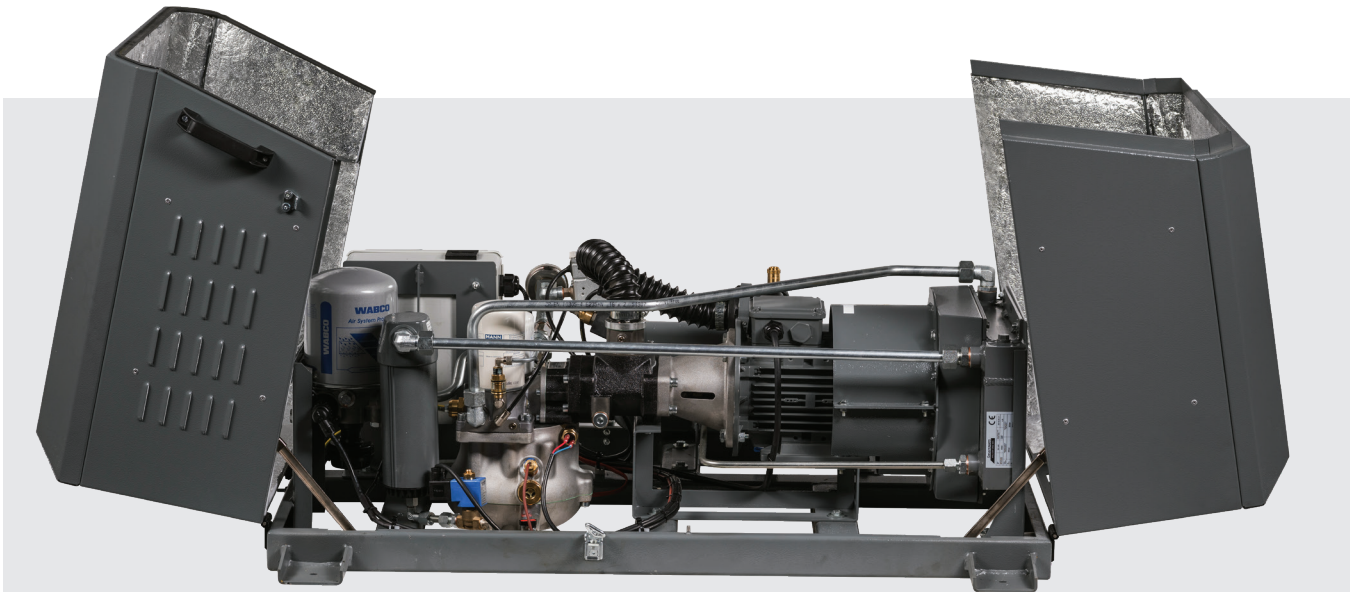

MULTI-BLOCK

- Oil separator filter
- Minimum pressure valve
- Thermostatic valve

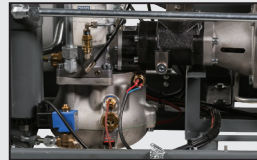

TECHNICAL DATA

MODEL	Pressure		Capacity*		Motor Power	Connection size	Dimensions (mm)			Weight	Noise**
	bar	psi	L/min	cfm	kW/HP		Length	Width	Height	kg	dB(A)
RSC 4S	10	145	310	11	3 / 4	G 1/2"	1100	886	485	125	67
TIDY 7D-M	7	100	650	23	5,5 / 7	G 1/2"	1000	550	625	205	69
RSC 10	10	145	800	28	7,5 / 10	G 1/2"	1328	940	540	235	69
RRC 2	8	115	130	4,6	1,1 / 1,5	G 1/2"	1100	886	485	115	72

- Unit performances measured in reference conditions which are 1 bar absolute air Pressure, %0 relative humidity, 20°C inlet air temperature, 71°C thermostatic valve set temperature and use of Smartoil.
- DALGAKIRAN compressors reserves its rights to make changes in its products and specifications without prior notice.
- * Refers to free air delivery measured according to ISO 1217:2009, Annex C standard.
- ** Refers to sound Pressure level measured according to ISO 2151:2004 and ISO 9614/2 with ± 3 dB(A) tolerance.