

# DALGAKIRAN



## DBK GP SERIES RECIPROCATING BOOSTER AIR COMPRESSORS



### STANDARD EQUIPMENT

High quality components such as IP55 electric motors with the IE3 efficiency class, star-delta motor starter system, electrical materials selected according to IEC, UL/cUL, CE standards as per the market requirements, durable compressor blocks are provided as standard in all our products.



### RELIABILITY

DALGAKIRAN pressurizes the air entering the compressor at 7-13 bar up to 40 bars with the DBK GP series booster compressors in its production range. The DBK GP series products have been preferred by PET bottle manufacturers for many years and have been successfully used in many companies.

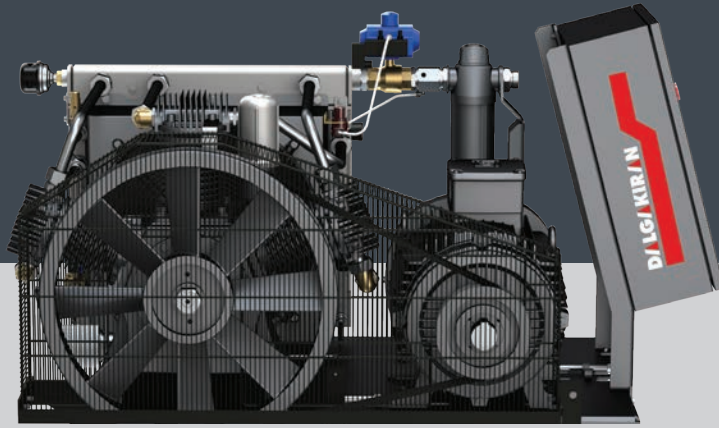

## MAIN MOTOR AND DRIVE SYSTEM

- High efficiency 400V/3 phase/50Hz IE3 IP55 electric motor
- Special loadless start system and automatic discharge system for loadless start



## COMPRESSOR BLOCK

- Cast iron cylinder with cooling fins and special aluminium alloy cylinder heads
- Specially designed high-speed stainless steel concentric valves.
- Cast iron crankcases with high strength
- Dynamically-balanced cast steel crankshaft and counterweight
- Special alloy aluminium pistons and steel cast connecting rods
- Stainless steel suction-discharge valves, specially designed for high pressure strength



## CONTROLLER

- Internal phase protection relay function
- Function for monitoring the mains voltage and frequency and keeping these at specified limits
- Multiple compressor control with up to 8 compressors without requiring an external main controller
- ModBus communication feature
- Alarm History Record for the last 9 alarms





## DBK GP SERIES Reciprocating Booster Air Compressors

DALGAKIRAN pressurizes the air entering the compressor at 7-13 bar up to 40 bars with the DBK GP series booster compressors in its production range. The DBK GP series products have been preferred by PET bottle manufacturers for many years and have been successfully used in many companies.

### MAIN MOTOR AND DRIVE SYSTEM

- Belt-pulley drive system
- Specially designed fan type cast iron pulley
- Easy belt tensioning system

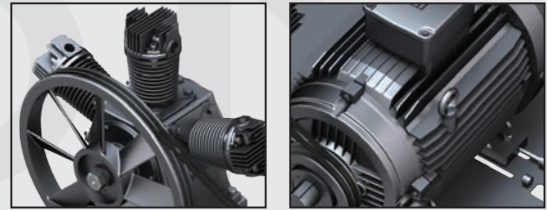

### SAFETY SYSTEMS

- Intake air control system
- High pressure switch
- Manual drain valve
- Integrated check valve on the air discharge line
- Belt pulley housing grill
- Outlet pressure manometer
- High pressure relief valve
- Oil pressure control
- Integrated particulate filter at the inlet
- By-pass line for protection against high oil pressure



### OTHER FEATURES

- Automatic discharging system for no-load start
- Durable sliding bearings
- Bar-Plate type after cooler
- Integrated oil and air cooler with inlet collector
- Air intake filter and muffler for no-load operation
- Oil gear pump
- Dedicated discharging system for preventing oil discharge from the blowdown valve

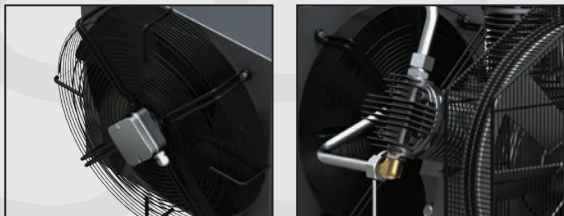

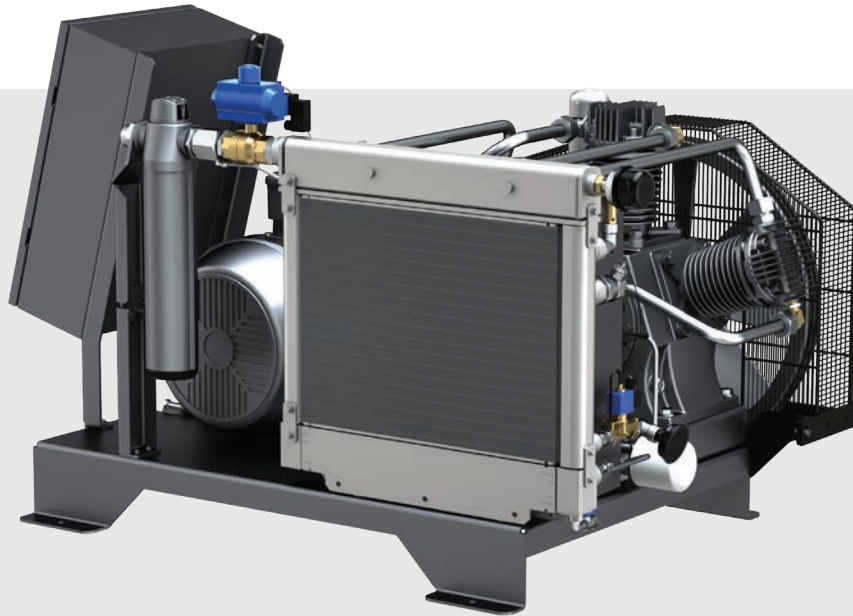

### OPTIONS

- High pressure air dryer
- High pressure air tank made of CE certified P265GH pressurized container steel (EN 286-1)
- Air filtering system with oil trap
- Food grade oil option
- Main motor with IE4 efficiency class



## TECHNICAL DATA

Model	Maximum Pressure*		Capacity (intake)						Motor Power	Connection Size	Dimensions (mm)			Weight
			7 bar (inlet)		10 bar (inlet)		13 bar (inlet)				Length	Width	Height	
	bar	psi	L/min	cfm	L/min	cfm	L/min	cfm	kW/HP	kg				
<b>DBK 10 GP</b>	40	580	2099	74	2886	102	3673	130	7,5/10	G 1"	1430	1010	1025	350
<b>DBK 15 GP</b>	40	580	2452	87	3371	120	4290	152	11/15	G 1"	1430	1010	1025	400
<b>DBK 20 GP</b>	40	580	3750	132	5150	182	6550	232	15/20	G 1"	1430	1010	1025	410
<b>DBK 25 GP</b>	40	580	4896	173	6732	238	8568	303	18,5/25	G 1 1/4"	1500	1025	957	440
<b>DBK 30 GP</b>	40	580	5564	197	7650	270	9736	344	22/30	G 1 1/4"	1500	1025	957	480
<b>DBK 40 GP</b>	40	580	6676	236	9180	324	11684	413	30/40	G 1 1/4"	1500	1025	957	550

- DALGAKIRAN compressors reserves its rights to make changes in its products and specifications without prior notice.

\* For 7 bar inlet pressure, max. discharge pressure is 35 bar.