

The Winning Force

**DURMA**

# AD-S SERIES PRESS BRAKES



- Perfect Precision
- Deep And Fast Bending
- Efficient
- Winning
- Elegant Design



**DURMA** The Winning Force





As a total supplier for sheet metal manufacturing with almost 60 years of experience, Durma understands and recognizes the challenges, requirements and expectations of the industry. We strive to satisfy the ever higher demands of our customers by continuously improving our products and processes while researching and implementing the latest technologies.

In our three production plants with a total of 150.000 m<sup>2</sup>, we dedicate 1,000 employees to delivering high quality manufacturing solutions at the best performance-to-price ratio in the market.

From the innovations developed at our Research & Development Center to the technical support given by our worldwide distributors, we all have one common mission: to be your preferred partner.

Present Durmazlar machines with **DURMA** name to the world.



1

High technology,  
modern production  
lines



2

Top quality  
components



3

High quality  
machines designed  
in R&D Centre

# The Winning Force

## Feel The Force and Performance

Our Machines are shaped with our superior experience and state of art technology, special designed as well as excellent combined component its the fastest , most reliable and prices press brakes on its category.

With its rigid body structure, robust back gauge and high standard components it ensures long lasting and precision applications.

Therefore with *DURMA* press brakes you can always achieve perfect result.

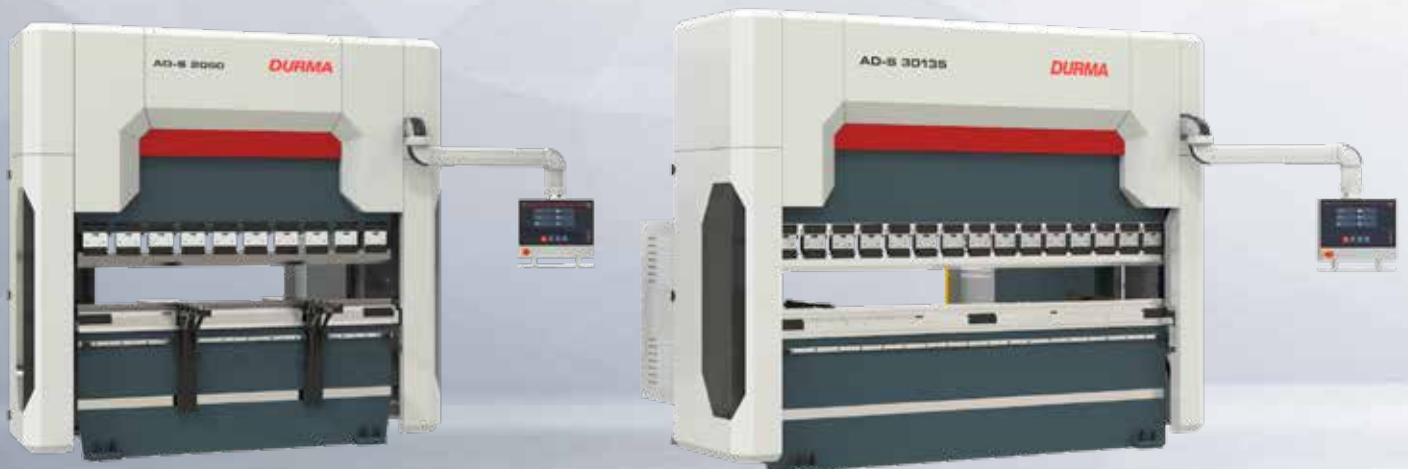



# Fast, Precise and Perfect Bending

- Precise bending result at fast speed
- Minimalized tool change and adjustment time
- Maximized speed and safety



# AD-S Series Press Brake



# Perfect and Fast Bending

## Perfect components for precision

With Easy to use control unit, stabile body structure, perfect design, low operating cost, different tool usage options, maximum safety standards, DURMA press brake is the best in the world in its segment.



**High  
Capacity**

**Robust  
Body**

**Perfect  
Precision**

**Winning**

**Ergonomic**

## Why *DURMA* Press Brakes

- Better and faster bending
- Stronger and rigid body structure
- High sensitivity and repeatability
- High technology excellent equipment
- Low service cost
- Reliability

# Fast, Efficient, Modern

AD-S Series press brakes, designed with high technology to increase efficiency on precise part bending.

Quality approved components.  
Stress relieved for long life and precise bending.



## General Specifications

- High sensitivity, Stress relieved steel construction body, long life Mono Block Frame
- Automatic calibration and first start up
- *DURMA* designed and copyrighted guiding system
- Ball Screw and linear guide integrated perfect back gauge system
- Durable, long life and sensitive bending capable special hardened top tools
- Suitable for segmented tools special and fast tool holding system
- Sensitive solutions on Long and deep bending
- High accuracy linear scales
- CE safety standards
- Best quality world wide accepted hydraulic and electric components





# Strong Back Gauge Systems

- Precise
- Reliable
- Strong

- Fast and high accuracy
- Safe movement
- Resistance to crash
- Maintenance free
- Adjustment availability at every point



CNC back gauge  
X - R  
Z manuel

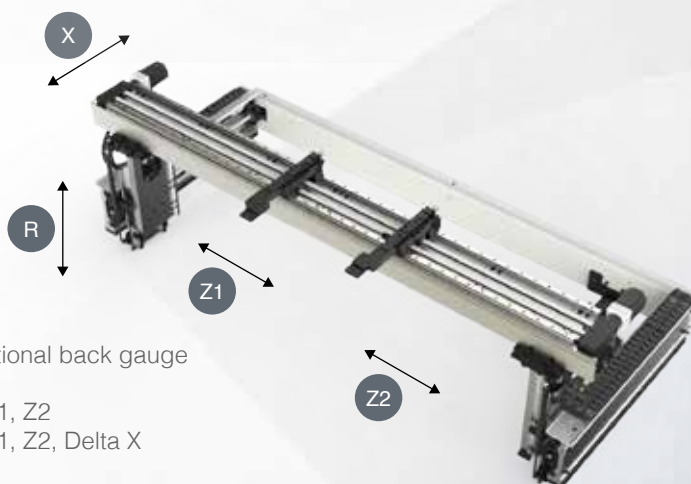

CNC optional back gauge  
X - R  
X - R - Z1, Z2  
X - R - Z1, Z2, Delta X

## Why *DURMA* Back Gauge ?

The most important feature to achieve perfect bending is the stability and the design of the back gauge, which allows an impeccable and correct product to be produced.

The high speed **ballscrew** back gauge system movement is also supported with **linear guides**, which helps the back gauge achieve long life, greater sensitivity and strengthens against any collisions.

Special designed finger blocks with steps to achieve maximum stability can also be supplied for every kind of bending solution.



CNC optional back gauge  
X1 - X2, R1 - R2, Z1 - Z2

# Tool Holders and Tools

Bending performance is increased by using high quality European clamping system and easiness to use. Narrow table designed for European style tool holder and Z bending.

*DURMA* is your solution partner with various tool options.



European Clamping System



European Type Bottom Tool (4V Die)



Quick Release Clamping



Wila Bottom Tool Clamping



Wila Top Tool Clamping



*DURMA* Bottom Tool Multi V



*DURMA* Top Tool

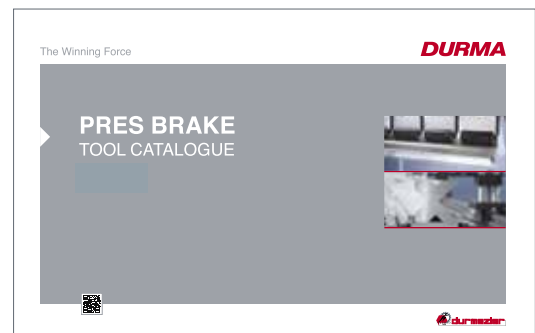

# Safe and Accurate Bends with Top Quality Equipments

## Crowning System

Manual or CNC-controlled motorized crowning system simplifies bending by adjusting each point of the bending parts to acquire straight bends. The need for shimming is eliminated.



## Linear Guide Front Sheet Supports

Rugged support arms with tilting stops are mounted on a linear guide rail system. This allows “finger-tip” lateral adjustment as required by the bend length of the part. They are also equipped with side gauges for the fast, easy, and accurate feeding of parts small or large.



Linear Guide Front Sheet Supports

## CE Safety Systems

Our machines are designed in accordance with Ce-Norms to ensure your safety with hydraulic, electric, appropriate height covers and laser light curtains. CE safety in tandem machines are also provided with light barriers.



Ce Laser Safety System

## Stable Top Beam Movement

By using long and planar guiding surfaces, all the disadvantages of point guiding are eliminated 100%. Free bending space: guiding system that eliminates bending between frame has been moved to the outside of the frame.

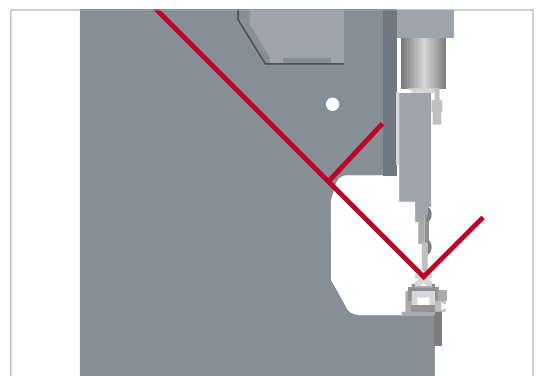

90 Degree Endless Bend

# Now Bending is More Easier

## SKY 22



- 21.5" TFT color touch screen with USB port and backup
- Automatic bending order
- Perfect control of electrical servo systems
- Archiving user bendings
- 2D/3D color graphics display and multi-simulation
- Windows 10 operating system
- D-Bend offline software
- Tandem applications
- Network interface
- X1-X2-R1-R2-Z1-Z2 and AP3-AP4 part support system

## DA-66T



- 2D graphical touch screen programming mode
- 3D visualisation in simulation and production
- 17" high resolution colour TFT
- Full Windows application suite
- Delem modusys compatibility
- USB, peripheral interfacing
- User specific application support within the controllers multitasking environment
- Sensor bending & correction interface
- Profile - TL - software

## DA-69T



- Higher grade of efficiency
- 3D and 2D graphical touch screen programming mode
- 17" high resolution colour TFT
- Delem modusys compatibility
- Sensor bending correction interface
- 1 GB memory capacity
- Integrated OEM-Panel
- 1280x1024 pixels, 16-bit colour
- 3D graphics acceleration
- Profile - T - 3D software



System of DURMA Angle Measurement



Automatic AP3 - AP4 Sheet Follower

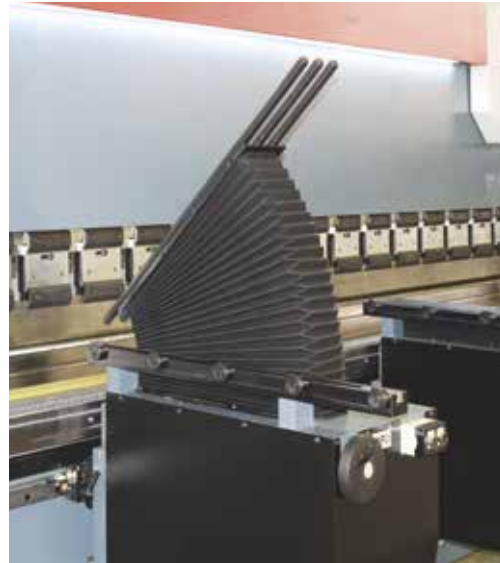

Robotic System of Applications





# Standard & Optional Equipment

## Standard Equipment

Y1, Y2, X, R - 4- Axis  
Control Unit - CNC SKY 22  
CE Manuel F. AKAS II M FPSC-B-C + light barriers  
CE F.AKAS BVL T Light barrier and safety cages (For Tandem Press Brakes)  
Servo motor back gauge & linear guided & ballscrew system  
CNC controlled motorized Crowning  
European style tool clamping system  
Sliding front arms  
World standards special design hydraulic block and valves  
World standard electric equipment

## Optional Equipment

Control Unit - Delem 66 T  
Control Unit - Delem 69 T  
CE with FIESSLER AKAS-LC II AKAS - 3M Motorized + FPSC (SAFETY PLC)  
Motorized FIESSLER AKAS-3PM (distance of mute until 3)  
Delta X Axis  $\pm$  125 stroke  
X Axis = 1000 mm – light barrier back protection  
AP3-AP4 Automatic system of sheet follower – Motorized elevation adjustment  
( There is a motorized elevation adjustment of 220 tons or more.)  
Laser angle measurement (DAM)  
Quick release clamping system  
Hydraulic and pneumatic tool clamping systems  
Bottom and top tools  
Parking area  
Central lubrication system  
Oil cooler  
Additional back gauge finger and sliding front support arms  
Special packing for overseas shipments  
DBEND 3D bending simulation program

# Fast on Service and Spare Parts

DURMA provides the best level of service and spare parts with qualified personnel and spare parts in stock. Our experienced and professional service personnel are always ready at your service. Our professional training and application enriched courses will give you an advantage to use our machinery.



Consultancy



Spare Parts



R&D Center



After Sales Service

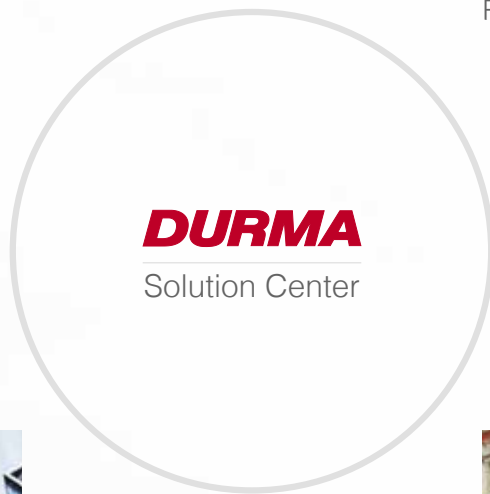

Service Agreements



Software



Training



Flexible Solution

# AD-S Series Technical Details

AD-S Series	Bending Force	Bending Length	Distance Between Columns		Stroke	Daylight	Throat Depth	Table Height	Table Width ( Narrow / Wide)	Working Speed						
			A	B						C	D	E	F	G	Y Rapid Speed	Y Working Speed
			mm	mm						mm	mm	mm	mm	mm	mm/sec.	mm/sec.
AD-S 2060	60	2050	1700	265	530	450	900	104	200	10						
AD-S 25100	100	2550	2200	265	530	450	900	104	180	10						
AD-S 30100	100	3050	2600	265	530	450	900	104/180	180	10						
AD-S 30135	135	3050	2600	265	530	450	900	104/180	160	10						
AD-S 30175	175	3050	2600	265	530	450	900	104/240	160	10						
AD-S 30220	220	3050	2600	265	530	450	900	104/240	140	10						
AD-S 30320	320	3050	2600	365	630	450	900	154/300	160	10						
AD-S 37175	175	3700	3100	265	530	450	900	104/240	140	10						
AD-S 37220	220	3700	3100	265	530	450	900	104/240	160	10						
AD-S 40175	175	4050	3600	265	530	450	900	104/240	160	10						
AD-S 40220	220	4050	3600	265	530	450	900	104/240	160	10						
AD-S 40320	320	4050	3600	365	630	450	900	154/300	160	10						
AD-S 40400	400	4050	3400	365	630	510	1050	154/300	140	8						
AD-S 40600	600	4050	3100	365	700	510	990	154/300	100	7						
AD-S 43175	175	4300	3750	265	530	450	900	104/240	160	10						
AD-S 43220	220	4300	3750	265	530	450	900	104/240	160	10						
AD-S 60220	220	6050	5100	265	530	450	1050	154/300	140	10						

Y Return Speed	Y Axis Precision	X Axis Working Speed
mm/sec.	mm	mm/se
110	0,01	500
120	0,01	500
120	0,01	500
120	0,01	500
100	0,01	500
140	0,01	500
140	0,01	500
100	0,01	500
120	0,01	500
140	0,01	500
140	0,01	500
120	0,01	350
80	0,01	350
140	0,01	500
140	0,01	500
120	0,01	350

Machines set according to optimum values.

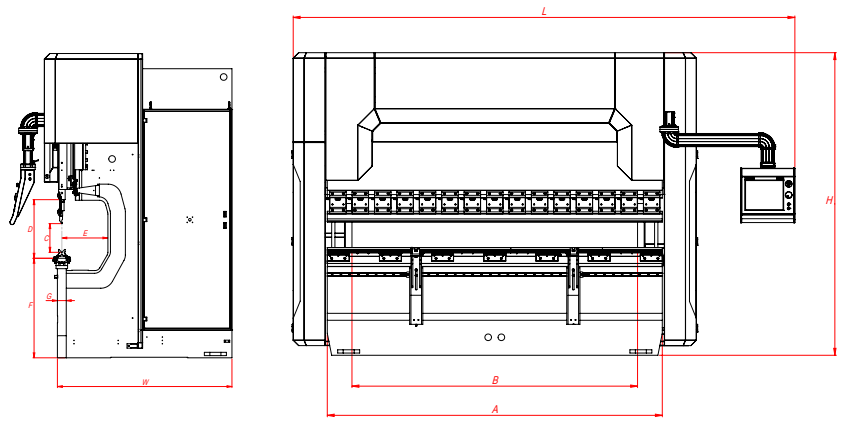

c.	X Axis Precision mm	X Axis Distances			R Axis Working Speed mm/sec.	R Axis Working Distance mm	R Axis Precision mm	Z Axis Working Speed (max.) mm/sec.	Z Axis Working Distance mm	Motor Power kW	Oil Tank Capacity lt	Length mm	Width mm	Height mm	Weight Approx. kg
		650 mm	750 mm	1000 mm											
												L	W	H	
	0,05	S	-	O	350	250	0,1	1000	1100	7,5	100	3200	1550	2850	5600
	0,05	S	-	O	350	250	0,1	1000	1580	11	100	3800	1670	2850	7800
	0,05	S	-	O	350	250	0,1	1000	1990	11	100	4200	1670	2850	8500
	0,05	S	-	O	350	250	0,1	1000	1990	15	150	4200	1680	2850	9580
	0,05	S	-	O	350	250	0,1	1000	1990	18,5	250	4250	1700	2850	10900
	0,05	S	-	O	350	250	0,1	1000	1990	22	250	4250	1770	3000	12600
	0,05	S	-	O	350	250	0,1	1000	1990	37	250	4300	1820	3330	17100
	0,05	S	-	O	350	250	0,1	1000	2375	18,5	250	4950	1700	3000	11750
	0,05	S	-	O	350	250	0,1	1000	2375	22	250	4950	1770	3000	14440
	0,05	S	-	O	350	250	0,1	1000	2910	18,5	250	5250	1700	2850	12780
	0,05	S	-	O	350	250	0,1	1000	2910	22	250	5250	1770	3000	14750
	0,05	S	-	O	350	250	0,1	1000	2910	37	250	5300	1910	3330	20000
	0,05	-	S	O	300	250	0,1	1000	2670	37	500	5750	2110	3640	27760
	0,05	-	S	O	300	250	0,1	1000	2670	45	500	5750	2500	4000	40500
	0,05	S	-	O	350	250	0,1	1000	2910	18,5	250	5950	1770	3000	13600
	0,05	S	-	O	350	250	0,1	1000	2910	18,5	250	5950	1770	3000	15550
	0,05	-	S	O	300	250	0,1	1000	4400	22	250	7500	1770	3350	20800

S : Standard

O : Optional

# Special projects













**DURMA**



PANEL BENDER



PUNCH



PLASMA



L ANGLE PROCESSING CENTER



IRON WORKER



POWER OPERATED SHEAR



PRESS BRAKE



VARIABLE RAKE SHEAR



TUBE LASER CUTTING

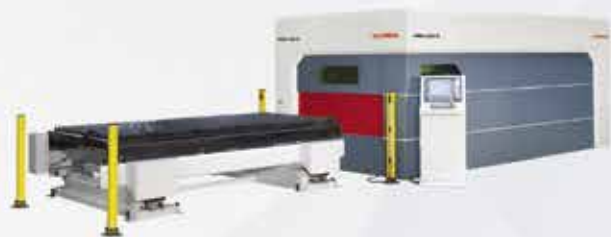

FIBER LASER



ROLL BENDING



PROFILE BENDING



CORNER NOTCHER



# DURMA

V	b	r <sub>i</sub>	s(mm)																					
			0.5	0.8	1	1.2	1.5	1.8	2	2.5	3	3.5	4	4.5	5	6	7	8	9	10	12	15	18	20
6	5	1	2,5	6,5	10																			
8	6	1,3	2	5	8	11																		
10	7	1,7	1,5	4	6	9	13																	
12	9	2		3	5	7	11	16																
15	12	2,7			4	6	9	13	16															
20	15	3,3				4	7	10	12	19														
26	18	4,2					4	7,5	9	14	21													
30	22	5						6,5	8	12	19	24												
32	23	5,4							7,5	11,6	17	23	30											
37	25	5,8								10	14,5	20	26	33										
42	29	6,7									13	17	23	29	33,5									
45	32	7,5										16	21	27	33	48								
50	36	8,3											19	24	30	43	58							
60	43	10												20	25	36	49	64						
70	50	11,5													21	31	42	55	69					
80	57	13,5														27	37	48	60	75				
90	64	15															32	42	54	66	95			
100	71	17																38	48	60	86	134		
130	93	22																	37	46	66	103	149	
180	130	30																		33	48	75	107	153
200	145	33																			43	67	83	119
250	180	42																				54	77	92

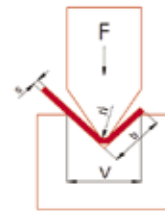

$$F = \frac{1,42 \times L \times Rm \times s^2}{1000 \times V} \text{ (Ton)}$$

F: Bending Force (Ton) L: Length (mm) Ri: Inside Radius (mm) Rm: Material Tensile Strength (daN/mm²) V: Channel Width (mm) B: Minimum Sheet Bending Side (mm) S: Thickness (mm)

## AD-S SERIES PRESS BRAKES